

SWS (HG12, DXD, DXE & C Range) - Low Type Retrofit Vacuum Circuit Breaker

SPE Energy Ltd is at the forefront of Retrofit Vacuum Circuit Breaker (RVCB) design and manufacture with the new, SWS-Lo RVCB using a proven motor-spring stored-energy mechanism (auto-reclosing type) to provide stabilised electrical and mechanical characteristics.

The exceptional insulation characteristics of a Vacuum Interrupter (VI) permits it to react rapidly from small current to short-circuit currents, allowing for a stable interrupting performance in double earth fault and out-of-phase currents. Vacuum offers the highest insulating strength and a far superior arc quenching properties than any other medium on the market i.e., Air, Oil and SF6.

SPE Energy designed the SWS-Lo RVCB's to be a direct Oil Circuit Breaker exchange unit, incorporated all the existing features of the original unit but incorporating new vacuum technology. Therefore, you receive a fully interlocked, direct exchange, roll-in/roll-out unit.

SPE Energy RVCB's provide a quality, cost effective, environmentally friendly, and lower-maintenance alternative to increase the life of your existing Switchgear with minimal or no supply disruption with improved performance and increased reliability.



Advantages of SWS RVCB's

- Replacing Circuit Breaker only is a significant reduction in time and resources needed for planning and execution, when compared with complete Switchboard replacement.
- Considerable overall cost savings compared with Switchboard replacement.
- Enables a phased controlled replacement, spreading cost over a definitive period.
- No site disruption.
- Installation involves no civil work.
- Removal of oil from the substation reduces the risk of fire and explosion, which leads to lower insurance premiums.
- Increased operating reliability and reduced maintenance costs, the Mechanism is rated M2
- No need to disturb or replace HV cables
- Circuit Breaker can be remotely operated.
- An automated Raise/Lower device, for local and/or remote operation, can be included on request.
- Suitable for frequent switching duties
- Replaces the dangerous and environmentally damaging SF6 gas.
- Significantly extends the service life of the fixed housing.
- Contributes to company environmental sustainability policy and reduces carbon footprint through the better use of natural resources and a reduction in raw materials.



SWS (HG12, DXD, DXE & C Range) - Low Type

Retrofit Vacuum Circuit Breaker

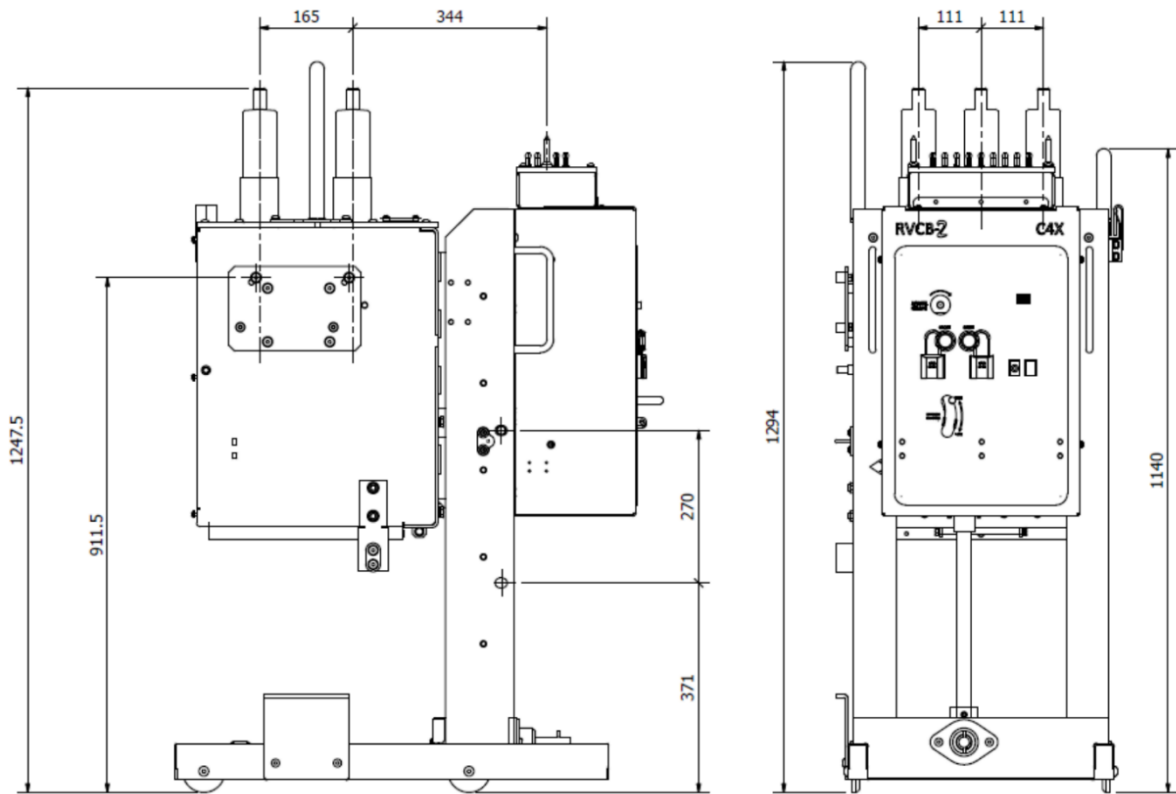

Figure 1. SWS-Lo RVCB Dimensions

Description	Ratings
Rated Maximum Voltage (Ur), (kV rms)	12
Power frequency insulation level withstand (kV), 1 min dry	28
Rated lightning impulse withstand voltage (BIL), (kVp)	75
Rated power frequency (fr), (Hz)	50/60
Rated continuous current (Ir), (A rms)	400/630/800/1250
Rated short-time withstand current (Ik), 3 secs, (kA rms)	25 *
Rated peak withstand current (I _p), (kA)	62.5 *
Rated control voltage, DC volts	77-121
Rated symmetrical interrupting current (I _{sc}), (kA rms)	25
Rated dc component (%)	50
Rated operating sequence	0-0.3s-C0-15s-C0
Mechanical operating sequences, Class M2	10000
Operating temperature range, °C	-5 to +40
Relative humidity (%)	0-100
Maximum altitude above sea level, m	1000



The 25kA RVCB complies to the following IEC standards: -

- IEC 62771-100 High Voltage Switchgear and control gear - Alternating current earthing devices
- IEC 62271-1 High Voltage Switchgear and control gear – Common specifications
- IEC 62271-102 High Voltage Switchgear & Control Gear – Alternating current disconnectors & earthing switches